

ENJOY THE **SAFETY**

**STOP+pflex**<sup>®</sup>  
FOR PRESSURE HOSES

**Sistema di Trattenimento per Tubi Flessibili in Pressione**  
*Retention System for Pressure Hoses*

ITA/EN  
V. 2019-05-02

**IT'S**  
FLUIDMEC  
WORLD

Member of

[www.fluidmecworld.com](http://www.fluidmecworld.com)

**op**<sup>®</sup>  
PEOPLE, PASSION  
& **SOLUTIONS**

# SICUREZZA TESTATA PER GLI IMPIANTI OLEODINAMICI

## *For safer plants*

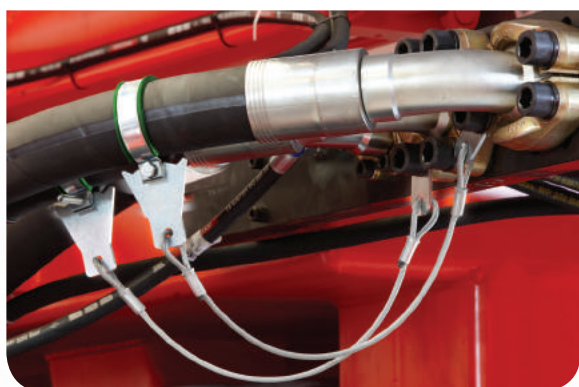

## INTERNATIONAL PATENT

### ISO 4413 TRASMISSIONI IDRAULICHE, REGOLE GENERALI RELATIVE AI SISTEMI:

“Se la rottura di una tubazione flessibile costituisce rischio, questa deve essere trattenuta o schermata”.

### ISO 4413 HYDRAULIC FLUID POWER, GENERAL RULES RELATING TO SYSTEM:

“Should the rupture of a hose assembly represent a whiplash hazard, the latter shall be restrained or shielded”.

**IHSA**  
International  
Hydraulic Safety Authority

“The International Hydraulic Safety Authority is the world leader in hydraulic safety training. Our hydraulic safety content as it relates to systems, occupational and environmental safety is the most comprehensive training available in this subject matter.

**In regards to hose restraints IHSA high recommends the use of the Stopflex system.**

*In some jurisdictions hose whip restraints are required by law where there is risk to personnel from whipping hoses.”*

### ESPOSITORI DISPONIBILI SU RICHIESTA PER I NOSTRI RIVENDITORI.



### DISPLAY RACKS AVAILABLE UPON REQUEST FOR OUR DEALERS.

## GARANZIA DI SICUREZZA

La forza sprigionata da un tubo flessibile in pressione, in caso di sfilamento dal raccordo, potrebbe risultare molto pericolosa per cose o persone nelle vicinanze. Il sistema di trattenimento Stopflex è stato ideato per arrestare la corsa del tubo sfilato ed evitare che la forza sprigionata al suo interno possa innescare un temibile "effetto frusta". Grazie al sistema Stopflex, infatti, il tubo flessibile viene ancorato tramite una fune all'impianto garantendo così la piena tutela degli operatori e la salvaguardia dei componenti.

## SAFETY GUARANTEE

*The energy contained within a pressure hose, in case of disconnection from the fitting, can be very dangerous to anyone or anything in its vicinity. The Stopflex retention system was designed to arrest the trajectory of the flexible hose, thus avoiding that the energy contained inside may trigger a frightening "whip effect". As a matter of fact, thanks to the Stopflex system, the hose is secured to the plant by means of a cable protecting both the operators and components.*

## FLESSIBILITÀ DI UTILIZZO

I componenti Stopflex possono essere applicati a tutti i tipi di tubo flessibile. La fascetta, munita di guarnizione, rimane perfettamente ancorata al tubo pur consentendo alla condotta di polmonare in base alla pressione di esercizio. L'ancoraggio può essere applicato a nipples, a flange SAE o a diversi componenti dell'impianto.

## USE FLEXIBILITY

*Stopflex components can be applied to all kinds of flexible hoses. A band, equipped with a rubber gasket, remains perfectly secured, simultaneously allowing the hose to swell according to the working pressure. The retaining components can be secured to nipples, to SAE flanges or other system components.*

## PROTEZIONE COLLAUDATA

Il sistema Stopflex, previo corretto montaggio, è stato realizzato e collaudato per garantire il trattenimento del tubo fino alla pressione massima indicata nel presente catalogo facendo riferimento alle seguenti norme che regolano la costruzione dei tubi flessibili oleodinamici:

EN 853 EN 854 EN 855  
EN 856 EN 857 SAE J517

## TESTED PROTECTION

*The Stopflex system, upon correct mounting, was manufactured and tested to ensure the retention of the hose up to the maximum pressure indicated in this catalogue in compliance with the following standards regulating the manufacture of hydraulic flexible hoses:*

EN 853 EN 854 EN 855  
EN 856 EN 857 SAE J517

**Non adatto a tubazioni contenenti aria o gas in pressione**

### **N.B.**

Esistono sul mercato tubazioni flessibili oleodinamiche che potrebbero superare le pressioni indicate nel presente catalogo ed in presenza delle quali vi invitiamo a contattare il nostro ufficio tecnico per ulteriori verifiche dell'applicazione.  
E-mail: [service@op-srl.it](mailto:service@op-srl.it)

**Not suitable for high pressure air and compressed gas hoses**

### **N.B.**

*In the market there are hydraulic flexible hoses capable of exceeding the pressures indicated in this catalogue. In case you encounter such hoses, please contact our technical department for further ascertainment regarding application thereof.*  
E-mail: [service@op-srl.it](mailto:service@op-srl.it)

# PRINCIPI DI FUNZIONAMENTO

## *Basics of use*

### **1ª FASE: SFILAMENTO**

Il sistema Stopflex non entra in funzione durante la fase di sfilamento del tubo flessibile ma, se applicato correttamente, fa in modo che il tubo si sganci completamente dalla bussola che lo trattiene.

#### **STEP 1: DISENGAGEMENT**

*The Stopflex system does not operate during the step of disengaging the flexible hose, but, if applied correctly, it ensures that the hose is fully disengaged from the ferrule that restrains it.*

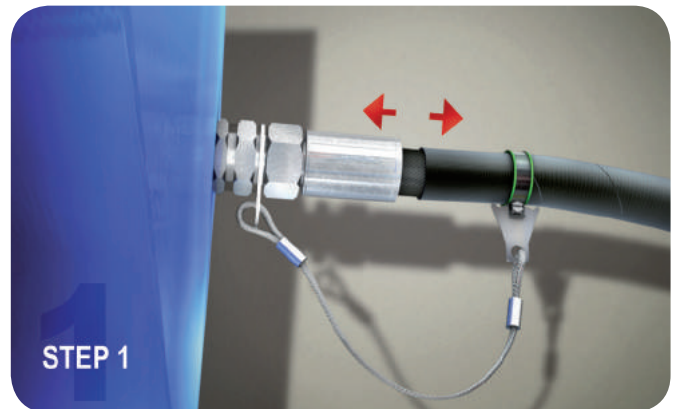

### **2ª FASE: RILASCIO / SFOGO DELLA PRESSIONE**

Durante questa fase l'olio in pressione fuoriesce dal tubo flessibile che acquista velocità e potenza, innescando un temibile effetto frusta, molto pericoloso per cose e persone nelle vicinanze.

#### **STEP 2: RELEASE / VENTING OF PRESSURE**

*During this step, the pressurised oil exits from the flexible hose. The hose begins to release the energy contained therein, and gains considerable velocity, triggering a hazardous "whip effect" which is very dangerous to anyone or anything in its vicinity.*

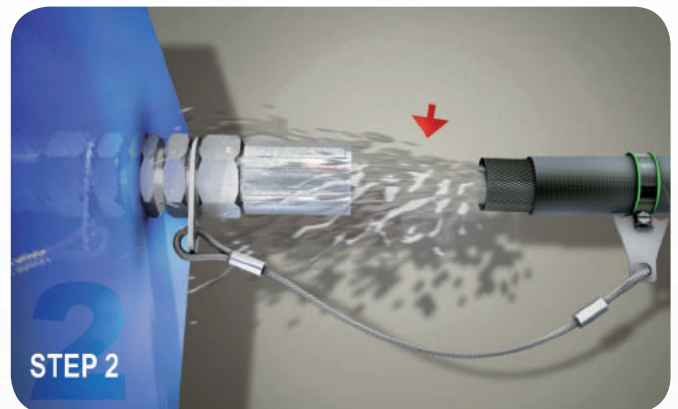

### **3ª FASE: TRATTENIMENTO**

Sfilato il tubo e sfogata la pressione, il tubo flessibile deve quindi essere trattenuto, ed è in questa fase che entra in funzione il sistema Stopflex: la fune d'acciaio si tende e si deforma mentre la piastrina incide la gomma del tubo impedendo il distacco della fascetta, saldamente ancorata al tubo. Fascetta e piastrina cominciano a loro volta a deformarsi elasticamente assorbendo la forza scatenata dalla corsa del tubo flessibile. Si tratta di una fase molto critica che si verifica in poche frazioni di secondo durante le quali i materiali e le forme del sistema, precedentemente dimensionati e testati, arrestano la pericolosa corsa del tubo flessibile.

#### **STEP 3: RESTRAINT**

*Once the hose has been disengaged and the pressure released, the flexible hose can be restrained. This is where the Stopflex system gets into operation: the stainless steel cable is tensioned and deformed while the plate cuts into the rubber of the hose, preventing the clamp, firmly attached to the hose, from disengaging. The hose clamp and plate start to deform in turn, elastically absorbing the force released from the travel of the flexible hose. This is a critical step which occurs within just a few seconds in which the materials and the components of the system, previously sized and tested, stop the dangerous travel of the flexible hose.*

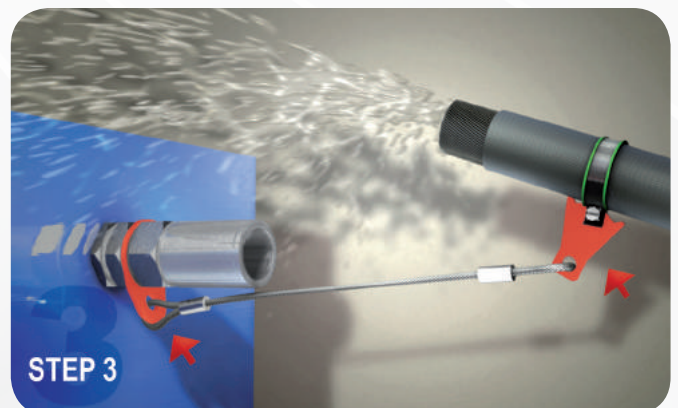

# PRINCIPI DI MONTAGGIO

## *Assembly basics*

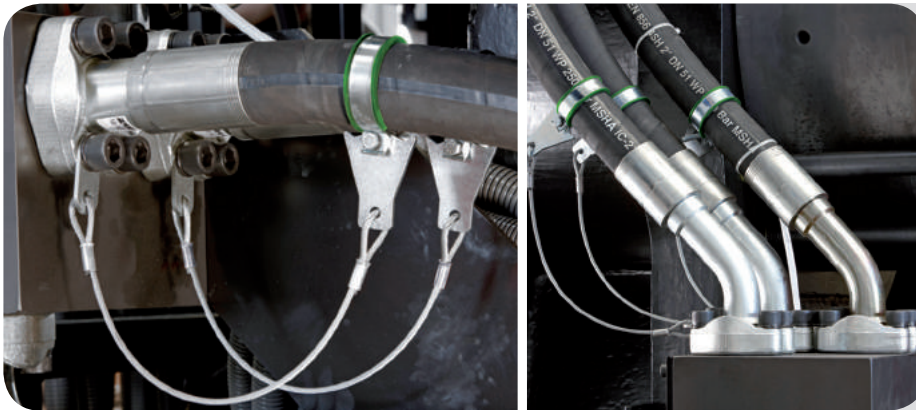

La procedura di montaggio dell'applicazione è fondamentale per garantire il corretto funzionamento del sistema Stopflex. Infatti, se non vengono eseguite correttamente le istruzioni di montaggio, esiste il fondato rischio che il sistema non funzioni. Dopo numerosi test su banchi di collaudo è stata trovata la combinazione ottimale fra materiali e procedimento di montaggio in modo da garantire la piena efficienza del sistema.

*The assembly procedure of the application is fundamental to ensure the correct operation of the Stopflex system. As a matter of fact, failure to carefully follow the assembly instructions, may actually jeopardise the operation of the system. After numerous tests on the test benches, we found the ideal combination of materials and assembly procedure to ensure the utmost efficiency in the system.*

- Condizioni ambientali particolari quali le luci ultraviolette, l'ozono, l'acqua salata, gli agenti chimici (solventi, carburanti, oli, grassi, composti chimici volatili, acidi, disinfettanti ed altri elementi aggressivi) possono provocare una precoce degradazione della guarnizione della fascetta;
- Provvedere alla sostituzione della guarnizione ogni 4 anni se la fascetta non viene assemblata;
- Provvedere alla sostituzione della guarnizione ogni 2 anni se la fascetta viene assemblata;
- Il sistema STOPFLEX non deve mai essere riutilizzato in caso di scoppio, sfilamento o sostituzione della tubazione, in quanto verrebbero a mancare le caratteristiche di sicurezza originali. In caso di riutilizzo la responsabilità ricade completamente sull'assemblatore.
- *Given environmental conditions such as ultraviolet light, ozone, salty water, chemical agents (solvents, fuels, oils, greases, volatile chemical compounds, acids, disinfectants and other aggressive elements) can cause early deterioration of the band seal;*
- *The seal must be replaced every 4 years if the band is not assembled;*
- *The seal must be replaced every 2 years if the band is assembled;*
- *The STOPFLEX system must never be re-used in case of hose rupture, slip-off or replacement of the hose, as this will jeopardise the initial safety features of the system. Should the system be re-used, the assembler will be held entirely liable therefor.*

## ELEMENTI DI TENUTA PER NIPPLI

### Nipple retention system

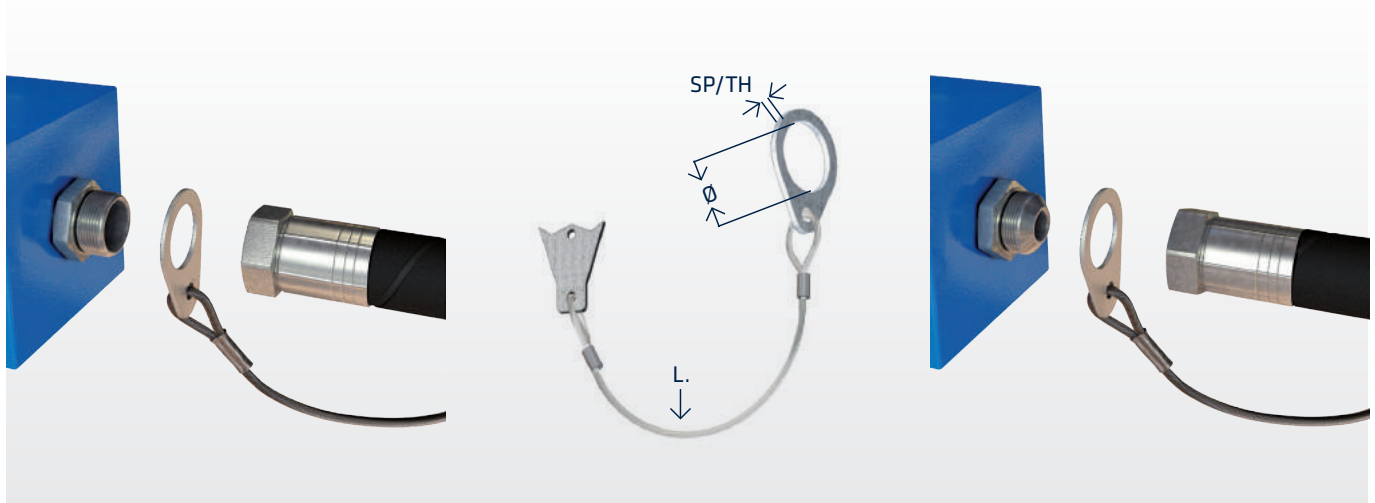

### RACCORDI CONICI A 24° (DIN)

#### 24° cone connectors (DIN)

CODICE CODE	ø M	ø mm ø inches	SP/TH mm inches	L. mm inches	Nr. Pezzi No. of PCS	Pressione Massima di lavoro bar - psi Max operating Pressure bar-psi	Piastrina incisione Cutting Plate
STOPFUDIN145	M6	14,5 0,571	2 0,079	300 11,811	10	450 6525	small
STOPFUDIN17	M6	17 0,669	2 0,079	300 11,811	10	445 6453	small
STOPFUDIN185	M6	18,5 0,728	2 0,079	300 11,811	10	420 6090	small
STOPFUDIN205	M6	20,5 0,807	2 0,079	300 11,811	10	420 6090	small
STOPFUDIN225	M6	22,5 0,886	2 0,079	300 11,811	10	420 6090	small
STOPFUDIN245	M6	24,5 0,965	2 0,079	300 11,811	10	420 6090	small
STOPFUDIN265	M6	26,5 1,043	2 0,079	300 11,811	10	420 6090	small
STOPFUDIN305	M6	30,5 1,201	2,5 0,098	300 11,811	10	420 6090	small
STOPFUDIN34	M8	34 1,339	2,5 0,098	450 17,717	10	420 6090	large
STOPFUDIN365	M8	36,5 1,437	2,5 0,098	450 17,717	10	420 6090	large
STOPFUDIN2365	M6	36,5 1,437	2,5 0,098	450 17,717	10	420 6090	large
STOPFUDIN425	M8	42,5 1,673	2,5 0,098	450 17,717	10	420 6090	large
STOPFUDIN455	M8	45,5 1,791	2,5 0,098	450 17,717	10	420 6090	large
STOPFUDIN2455	M6	45,5 1,791	2,5 0,098	450 17,717	10	420 6090	large
STOPFUDIN49	M8	49 1,929	2,5 0,098	450 17,717	10	420 6090	large
STOPFUDIN525	M8	52,5 2,067	2,5 0,098	450 17,717	10	385 5583	large
STOPFUDIN60	M8	60 2,362	2,5 0,098	450 17,717	10	350 5075	large

### RACCORDI CON SVASATURA A 37° (JIC)

#### 37° flared connectors (JIC)

CODICE CODE	ø M	ø mm ø inches	SP/TH mm inches	L. mm inches	Nr. Pezzi No. of PCS	Pressione Massima di lavoro bar - psi Max operating Pressure bar-psi	Piastrina incisione Cutting Plate
STOPFUJIC115	M6	11,5 0,452	2 0,079	300 11,811	10	450 6525	small
STOPFUJIC132	M6	13,2 0,519	2 0,079	300 11,811	10	450 6525	small
STOPFUJIC148	M6	14,8 0,452	2 0,079	300 11,811	10	450 6525	small
STOPFUJIC195	M6	19,5 0,767	2 0,079	300 11,811	10	420 6090	small
STOPFUJIC228	M6	22,8 0,897	2 0,079	300 11,811	10	420 6090	small
STOPFUJIC275	M6	27,5 1,082	2,5 0,098	300 11,811	10	420 6090	small
STOPFUJIC307	M6	30,7 1,208	2,5 0,098	300 11,811	10	420 6090	small
STOPFUJIC345	M6	34 1,339	2,5 0,098	450 17,717	10	420 6090	small
STOPFUJIC34	M8	34 1,339	2,5 0,098	450 17,717	10	420 6090	large
STOPFUJIC415S	M6	41,5 1,633	2,5 0,098	450 17,717	10	420 6090	small
STOPFUJIC415	M8	41,5 1,633	2,5 0,098	450 17,717	10	420 6090	large
STOPFUJIC48S	M6	48 1,889	2,5 0,098	450 17,717	10	420 6090	small
STOPFUJIC48	M8	48 1,889	2,5 0,098	450 17,717	10	420 6090	large
STOPFUJIC64	M8	64 2,519	2,5 0,098	450 17,717	10	350 5075	large

## ELEMENTI DI TENUTA APRIBILI PER NIPPLI RACCORDI CONICI A 24° (DIN)

### *Nipple retention system - open 24° cone connectors (DIN)*

Si tratta dell'evoluzione del sistema **STOPFLEX** creato per raccordi DIN. Grazie alle due parti di cui si compone, è possibile applicarlo ad impianti con tubazioni già montate.

*It's a further improvement of our **STOPFLEX** retention system designed for DIN fittings. Thanks to the two parts it is composed of, it can be installed on plants where hoses have already been assembled.*

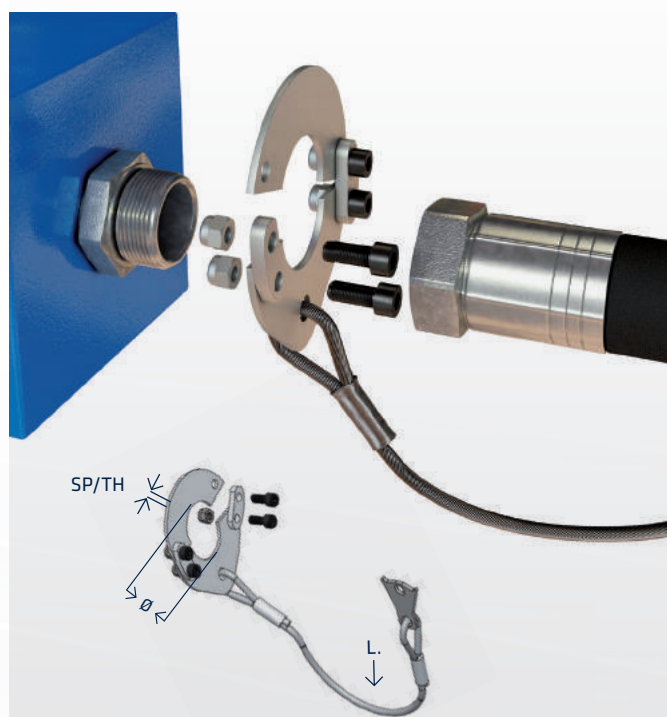

CODICE CODE	ø M	ø mm ø inches	SP/TH mm inches	L. mm inches	Nr. Pezzi No. of PCS	Pressione Massima di lavoro bar - psi Max operating Pressure bar-psi	Piastrina incisione Cutting Plate
STOPFUDIN145OP	M6	14,5 0,571	2 0,079	300 11,811	10	450 6525	small
STOPFUDIN170P	M6	17 0,669	2 0,079	300 11,811	10	445 6453	small
STOPFUDIN185OP	M6	18,5 0,728	2 0,079	300 11,811	10	420 6090	small
STOPFUDIN205OP	M6	20,5 0,807	2 0,079	300 11,811	10	420 6090	small
STOPFUDIN225OP	M6	22,5 0,886	2 0,079	300 11,811	10	420 6090	small
STOPFUDIN245OP	M6	24,5 0,965	2 0,079	300 11,811	10	420 6090	small
STOPFUDIN265OP	M6	26,5 1,043	2 0,079	300 11,811	10	420 6090	small
STOPFUDIN305OP	M6	30,5 1,201	2,5 0,098	300 11,811	10	420 6090	small
STOPFUDIN340P	M8	34 1,339	2,5 0,098	450 17,717	10	420 6090	large
STOPFUDIN365OP	M8	36,5 1,437	2,5 0,098	450 17,717	10	420 6090	large
STOPFUDIN425OP	M8	42,5 1,673	2,5 0,098	450 17,717	10	420 6090	large
STOPFUDIN455OP	M8	45,5 1,791	2,5 0,098	450 17,717	10	420 6090	large
STOPFUDIN490P	M8	49 1,929	2,5 0,098	450 17,717	10	420 6090	large
STOPFUDIN525OP	M8	52,5 2,067	2,5 0,098	450 17,717	10	385 5583	large
STOPFUDIN600P	M8	60 2,362	2,5 0,098	450 17,717	10	350 5075	large

## ELEMENTI DI TENUTA APRIBILI PER NIPPLI RACCORDI CON SVASATURA A 37° (JIC)

### *Nipple retention system - open 37° flared connectors (JIC)*

Si tratta dell'evoluzione del sistema **STOPFLEX** creato per raccordi JIC. Grazie alle due parti di cui si compone, è possibile applicarlo ad impianti con tubazioni già montate.

*It's a further improvement of our **STOPFLEX** retention system designed for JIC fittings. Thanks to the two parts it is composed of, it can be installed on plants where hoses have already been assembled.*

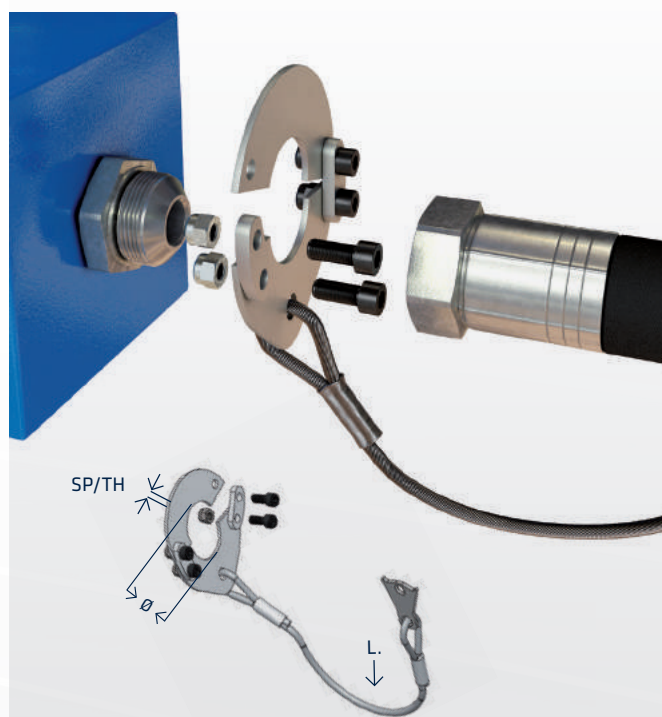

CODICE CODE	ø M	ø mm ø inches	SP/TH mm inches	L. mm inches	Nr. Pezzi No. of PCS	Pressione Massima di lavoro bar - psi Max operating Pressure bar-psi	Piastrina incisione Cutting Plate
STOPFUJIC115OP	M6	11,5 0,453	2 0,079	300 11,811	10	450 6525	small
STOPFUJIC132OP	M6	13,2 0,520	2 0,079	300 11,811	10	450 6525	small
STOPFUJIC148OP	M6	14,8 0,583	2 0,079	300 11,811	10	450 6525	small
STOPFUJIC195OP	M6	19,5 0,768	2 0,079	300 11,811	10	420 6090	small
STOPFUJIC228OP	M6	22,8 0,898	2 0,079	300 11,811	10	420 6090	small
STOPFUJIC275OP	M6	27,5 1,083	2,5 0,098	300 11,811	10	420 6090	small
STOPFUJIC307OP	M6	30,7 1,209	2,5 0,098	300 11,811	10	420 6090	small
STOPFUJIC345OP	M6	34 1,339	2,5 0,098	450 17,717	10	420 6090	small
STOPFUJIC340P	M8	34 1,339	2,5 0,098	450 17,717	10	420 6090	large
STOPFUJIC4155OP	M6	41,5 1,634	2,5 0,098	450 17,717	10	420 6090	small
STOPFUJIC415OP	M8	41,5 1,634	2,5 0,098	450 17,717	10	420 6090	large
STOPFUJIC485OP	M6	48 1,890	2,5 0,098	450 17,717	10	420 6090	small
STOPFUJIC480P	M8	48 1,890	2,5 0,098	450 17,717	10	420 6090	large
STOPFUJIC640P	M8	64 2,520	2,5 0,098	450 17,717	10	350 5075	large

## ELEMENTI DI TENUTA PER IMPIEGHI VARI

### Retention system for various uses



CODICE CODE	Ø M	Ø mm Ø inches	SP/TH mm inches	L. mm inches	Nr. Pezzi No. of PCS	Pressione Massima di lavoro bar - psi Max operating Pressure bar-psi	Piastrina incisione Cutting Plate
STOPFUVARIE	M8	13 0,512	4 0,157	450 17,717	10	420 6090	large
STOPFUVARIES	M6	10,5 0,413	4 0,157	450 17,717	10	420 6090	small

## ELEMENTI DI TENUTA PER FLANGE SAE 3000 E 6000

### Retention system for 3000 and 6000 sae flanges



CODICE CODE	Ø M	Ø mm Ø inches	SP/TH mm inches	L. mm inches	Nr. Pezzi No. of PCS	Pressione Massima di lavoro bar - psi Max operating Pressure bar-psi	Piastrina incisione Cutting Plate
STOPFUSAE085	M6	8,5 0,335	4 0,157	300 11,811	10	415 6018	small
STOPFUSAE2105*	M6	10,5 0,413	4 0,157	300 11,811	10	420 6090	small
STOPFUSAE105	M8	10,5 0,413	4 0,157	450 17,717	10	420 6090	large
STOPFUSAE125	M8	12,5 0,492	4 0,157	450 17,717	10	420 6090	large
STOPFUSAE2125	M6	12,5 0,492	4 0,157	450 17,717	10	420 6090	small
STOPFUSAE145	M8	14,5 0,571	4 0,157	450 17,717	10	420 6090	large
STOPFUSAE165	M8	16,5 0,650	4 0,157	450 17,717	10	420 6090	large
STOPFUSAE205	M8	20,5 0,807	4 0,157	450 17,717	10	350 5075	large
STOPFUSAE25	M8	25 0,984	8 0,315	550 21,654	10	350 5075	large
STOPFUSAE32	M8	32 1,260	8 0,315	550 21,654	10	210 3045	large

\* Applicazioni con flange SAE 3000 per tubi da 3/4".

\* Applications with SAE 3000 flanges for 3/4" hoses.

## FASCETTE STOPFLEX PER TUBO FLESSIBILE

### Stopflex hose bands

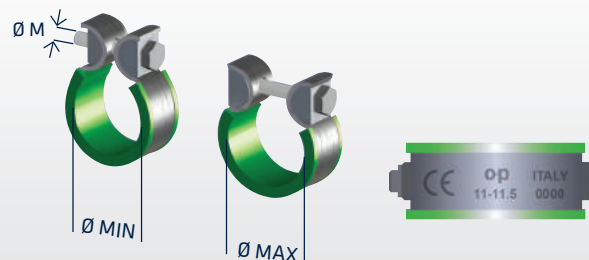

CODICE CODE	Ø M	Ø MIN		Ø MAX		Nr. Pezzi No. of PCS
		mm	inches	mm	inches	
STOPFA1115	M6	11	0,433	11,5	0,453	10
STOPFA12125	M6	12	0,472	12,5	0,492	10
STOPFA13135	M6	13	0,512	13,5	0,531	10
STOPFA1415	M6	14	0,551	15	0,591	10
STOPFA1617	M6	16	0,630	17	0,669	10
STOPFA1718	M6	17	0,669	18	0,709	10
STOPFA1819	M6	18	0,709	19	0,748	10
STOPFA2021	M6	20	0,787	21	0,827	10
STOPFA2122	M6	21	0,827	22	0,866	10
STOPFA2223	M6	22	0,866	23	0,906	10
STOPFA2425	M6	24	0,945	25	0,984	10
STOPFA2526	M6	25	0,984	26	1,024	10
STOPFA2627	M6	26	1,024	27	1,063	10
STOPFA2728	M6	27	1,063	28	1,102	10
STOPFA2829	M6	28	1,102	29	1,142	10
STOPFA3031	M6	30	1,181	31	1,220	10
STOPFA3233	M6	32	1,260	33	1,299	10
STOPFA3435	M6	34	1,339	35	1,378	10
STOPFA3637	M6	36	1,417	37	1,457	10
STOPFA3839	M6	38	1,496	39	1,535	10
STOPFA3940	M6	39	1,535	40	1,575	10
STOPFA4041	M6	40	1,575	41	1,614	10
STOPFA4243	M6	42	1,654	43	1,693	10
STOPFA4344	M6	43	1,693	44	1,732	10
STOPFA4445	M6	44	1,732	45	1,772	10
STOPFA4547	M8	45	1,772	47	1,850	10
STOPFA4850	M8	48	1,890	50	1,969	10
STOPFA5153	M8	51	2,008	53	2,087	10
STOPFA5456	M8	54	2,126	56	2,205	10
STOPFA5759	M8	57	2,244	59	2,323	10
STOPFA6062	M8	60	2,362	62	2,441	10
STOPFA6365	M8	63	2,480	65	2,559	10
STOPFA6668	M8	66	2,598	68	2,677	10
STOPFA6971	M8	69	2,717	71	2,795	10
STOPFA7274	M8	72	2,835	74	2,913	10
STOPFA7577	M8	75	2,953	77	3,031	10
STOPFA7880	M8	78	3,071	80	3,150	10
STOPFA8183	M8	81	3,189	83	3,268	10
STOPFA8486	M8	84	3,307	86	3,386	10
STOPFA8789	M8	87	3,425	89	3,504	10
STOPFA9092	M8	90	3,543	92	3,622	10
STOPFA9395	M8	93	3,661	95	3,740	10

NB: I diametri riportati in tabella sono indicativi, è possibile che al serraggio delle fascette questi varino leggermente.

NB: The diameters indicated in the table shall be deemed indicative. They could slightly vary upon tightening the band.



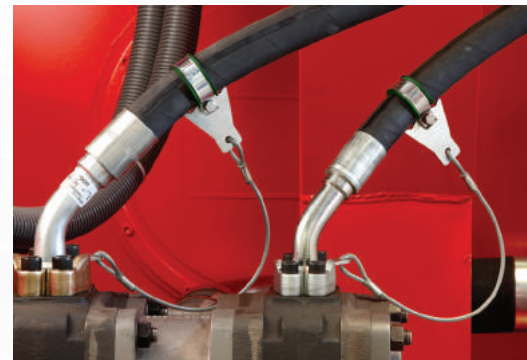
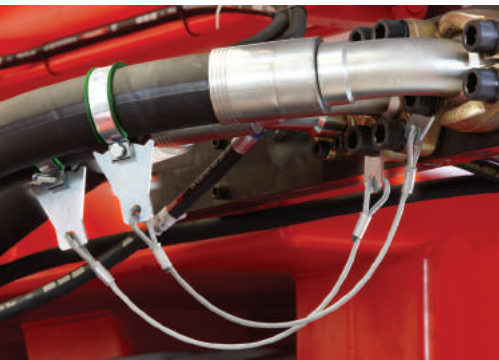

**STOPflex**<sup>®</sup>  
FOR PRESSURE HOSES

ENJOY THE **SAFETY**





[www.stopflex.it](http://www.stopflex.it)



 **OP Srl** - Via del Serpente, 97 - 25131 - Brescia - Italy  
Phone +39 030 35 80 401 - Fax +39 030 35 80 838 - [info@op-srl.it](mailto:info@op-srl.it) - [www.op-srl.it](http://www.op-srl.it)

 **OP Usa Inc.** - 6 Ledge Rock Way, Unit 4, Acton, MA, 01720 - USA  
[info@opusainc.com](mailto:info@opusainc.com) - [www.opusainc.com](http://www.opusainc.com)

 **OP (Shanghai)** Hydraulic Tubing Processing Equipment Co., Ltd  
Lane 3500 Xiupu Rd, Building A, Pudong, Shanghai PRC - 201315 - [sales@op-china.com](mailto:sales@op-china.com) - [www.op-china.com](http://www.op-china.com)

 **OP India Private Limited** 411, DLF Tower B, Jasola District Centre, New Delhi - 110076 - India  
[sales@op-india.com](mailto:sales@op-india.com) - [www.op-india.com](http://www.op-india.com)